

Glentek Radio to Ethernet (RTE) Controllers Installation and Operation manual

Caution: never control dangerous equipment using remote control. This includes equipment that, if improperly controlled, may cause property damage or personal injury. Glentek Corporation is not responsible for damages resulting from such use.

RTE-CIV Ethernet to Icom CI-V Controller (Radio to Ethernet)
RTE-232 Ethernet to RS232 Controller
Installation and Operation manual

Overview:

Before proceeding, make sure your rig control software is operating properly via the local RS232 connection and that you are familiar with its operation.

Note: the links in this document will work only in the Microsoft WORD versions.

The RTE-CIV controller provides a direct interface between a local Ethernet LAN connection and ICOM's CI-V computer control port. Likewise the RTE-232 provides a direct interface from a local Ethernet LAN connection to RS-232 enabled radios and other such as RS-232 enabled antenna rotators. The Ethernet interface can provide needed isolation between the station (antenna) ground and a local computer. With Internet access, remote station control is possible without the use of a PC at the radio end of the connection. This greatly improves system reliability and overall system security.

The controller is designed to "pass-through" commands sent by nearly any rig control program such as HR Deluxe. Remote operation is configured by "fooling" the rig control software into thinking it is running into a local RS-232 serial port. In reality, using the supplied COM PORT REDIRECTOR software, it will be sending the commands over the Ethernet where they will be received by the RTE and sent directly to the radio.

The converter has a built-in Web Server that allows configuration over an Ethernet connection.

Built-in features such as auto turn-on/off and PTT Timers eliminate radio lockups when Internet connections are lost and simplify the legal "3 minute timer" rule for remote operations. The controller provides 4 optically isolated outputs identified as K1, K2, K3, and K4:

- K1 ... photo transistor output activated by data detection
- K2 ... reserved for PTT (Push to Talk). Responds to command "F1"
- K3 ... general purpose. Responds to command "F2"
- K4 ... general purpose. Responds to command "F3"

Software Installation

The software requires installation of Microsoft's .NET framework. This comes pre-loaded on Vista systems, but earlier versions of Windows will require installation before



proceeding. The .Net v.3.5 software is on the CD, `dotNetFx35setup.exe` but it can also be downloaded here: [Microsoft download](#)

Two other programs need to be installed.

Software #1: DEVICE INSTALLER



The first is called DEVICE INSTALLER. Click on the `Di32DL_4.2.0.3_Web.exe` icon and follow the installation instructions. If somehow corrupted on the CD or it is lost, the latest version may be downloaded [HERE](#).

Connect the Glentek controller to an available LAN Ethernet port. Then connect the power supply. The power supply must be connected last to assure a proper device boot up.

Run DEVICE INSTALLER. This program will search the local LAN for Glentek controllers that are connected and will display them in a list format. The controller needs an address on your LAN. This is the IP address. If your router is set up for "DHCP", the DEVICE INSTALLER program and your router will automatically assign an address. It will look something like this:

192.168.0.123

It will also display the unique identifier of your module known as the MAC address. **Make a note of the IP address that has been assigned.** Lantronix has an extensive help file built in and on their website. If your device cannot be located, consult their help file or your administrator for assistance.

Double clicking on the listing will display the particulars of your device (name, etc.). Click on the web configuration tab to take you to the internal embedded server (leave password and username blank for now). Your RTE comes preset for operation at 19,200 bps communications speed. You must use the 19200 baud or 9600 rate if you wish to use the auxiliary outputs that respond to HEX codes. Otherwise, you may set the rate to anything you wish (as long as the radio is set to the same rate) but output ports 2,3, and 4 will not respond. If you have changed anything, click DONE and then apply settings.

Exit DEVICE CONTROLLER.

Software #2: REDIRECTOR – (CONFIGURATION)

Install COM PORT REDIRECTOR (Configuration) onto the computer where your RIG



control software resides by double clicking on the Cpr32DL_4.2.0.1_Web.exe icon on the CD and following the installation instructions. It may also be downloaded [HERE](#).

COM PORT REDIRECTOR (Configuration) is the software that we will use to “trick” your rig control software into thinking it is connected to a local hardware COM port. In reality, the software will intercept all communications in both directions and direct it to the Glentek IP address that you noted when you ran DEVICE INSTALLER. The Glentek controller will then convert the signals directly to CI-V or RS-232 codes that your radio will understand.

Start the COM PORT REDIRECTOR (Configuration) software.

Begin by clicking on the **COM SETUP** tab.

You will see as many as 80 choices for your new COM PORT. Ports that are already used by your computer are grayed out. This will probably include the hardware port that you used to use for your rig control software. Click on any of the remaining COM PORTs available. Remember this COM PORT number. You will have to direct your Rig control software to this new port.

Now, click on the **ADD IP** button

In the **HOST** textbox, enter the IP address that you found when running DEVICE INSTALLER. In the **TCPPort** textbox, enter the number 3001. This is the port number that was installed on your device when shipped. If you changed the TCPPort using DEVICE INSTALLER connection tab, enter that new port number instead. In case of trouble, go back and check the RTE embedded web page using DEVICE INSTALLER (connections tab) and make sure you use the same port number. Click OK to exit the **ADD IP** section.

Finally, click on the **PORT SETTINGS** button and make sure that the **RAW MODE** box is checked. On the main page, make sure the **SILENT MODE** box is unchecked. This will allow the display of the redirection progress and will aid in any necessary troubleshooting. Click **SAVE** and reboot your computer if directed to do so.

Go back to your RIG control software and point it towards the new COM port that you selected above. Connect the RTE to the Ethernet LAN jack and then power it up (8-18 volts DC at 300mA). Connect the radio CI-V jack to the CI-V output on the controller. With the RTE-232, connect the DB9 connector on the RTE directly to the RS-232 connector on the radio. Do not use a null modem cable. Make sure your computer is

connected to the same LAN and there are no blocking firewalls installed. Note: some Kenwood radios require hardware flow control. The RTE must be set accordingly using DEVICE INSTALLER.

Activating your rig control software should now directly connect to your radio as if it were a direct connection. If not, here are a couple of common problems to double check:

Make sure that the IP address (HOST) and TCP Port you entered into the COM PORT REDIRECTOR (configuration) software matches the settings in the Glentek controller. Check this by accessing the embedded web server using DEVICE INSTALLER software.

Your radio must be set to accept a 19200-baud rate regardless of the setting of your rig control software. This is because the RTE will accept any baud rate from the rig control software as an input, but will only output 19200 baud if the controller is set to that speed. If your radio does not support 19200 baud, you must change the speed settings of your RTE using its internal web server (under SERIAL SETTINGS) as accessed via the DEVICE INSTALLER software.

Make sure you have properly booted the RTE. This is done by applying power AFTER the RJ45 Ethernet connection is made.

Your router may not be allowing DHCP connections (automatic IP address assignments). This would have been apparent the first time you ran DEVICE INSTALLER since no IP address would have appeared. Consult your router manual on how to properly set up DHCP. As an alternative, you may force a particular IP address by using the internal web server in the Glentek controller. See the HELP files in DEVICE INSTALLER for details.

Check the LEDs mounted inside the RJ45 magjack connector. If they are not both flashing, the controller is not seeing any Ethernet activity. Check for proper LAN connections. Check to make sure that diode D8 (red) is illuminated and the green LED (D4) is off. This indicates that the controller is receiving data. In this case, check for proper radio settings and connections.

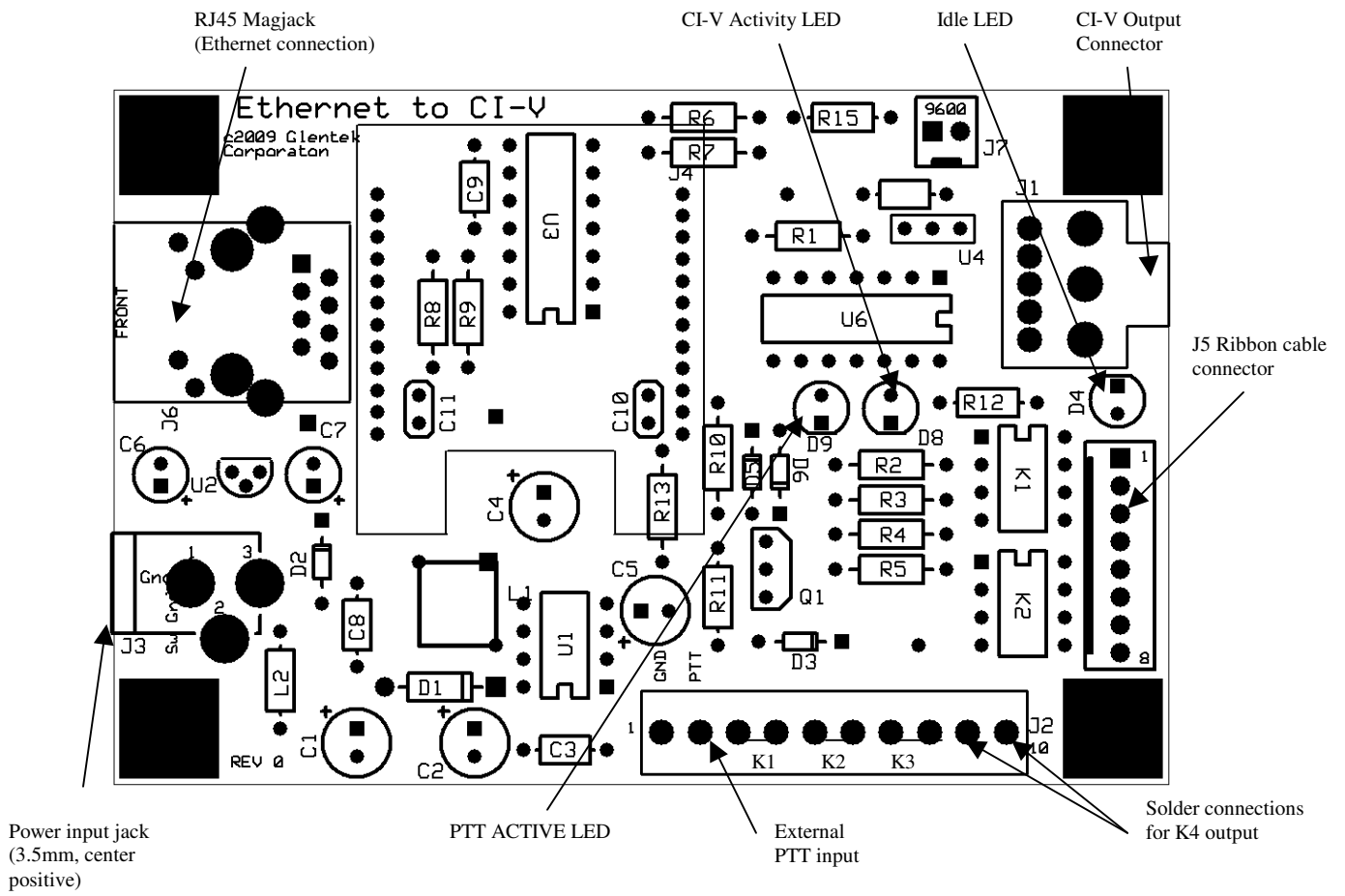

RTE-CIV Schematic:

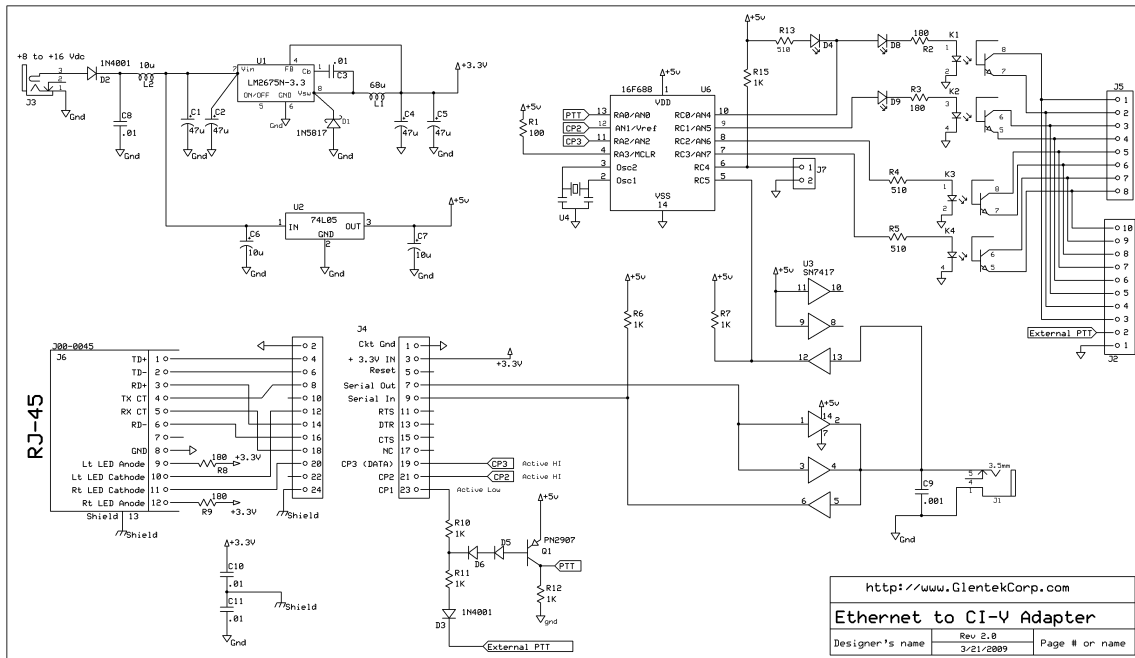

RTE-232 PCB layout:

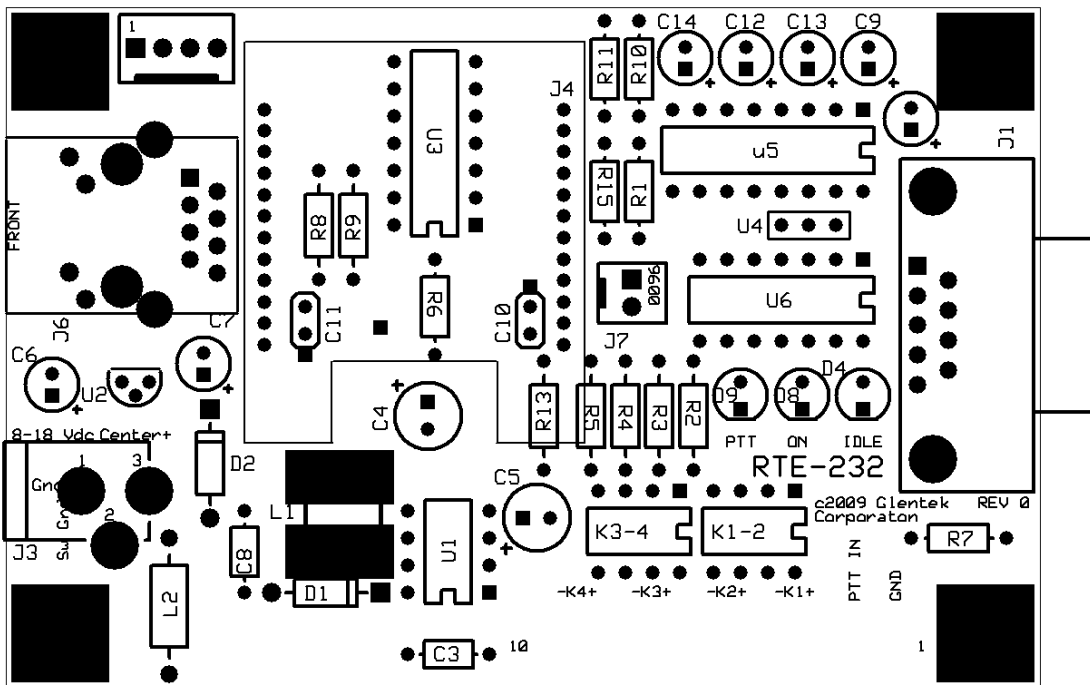

RTE-232 Schematic

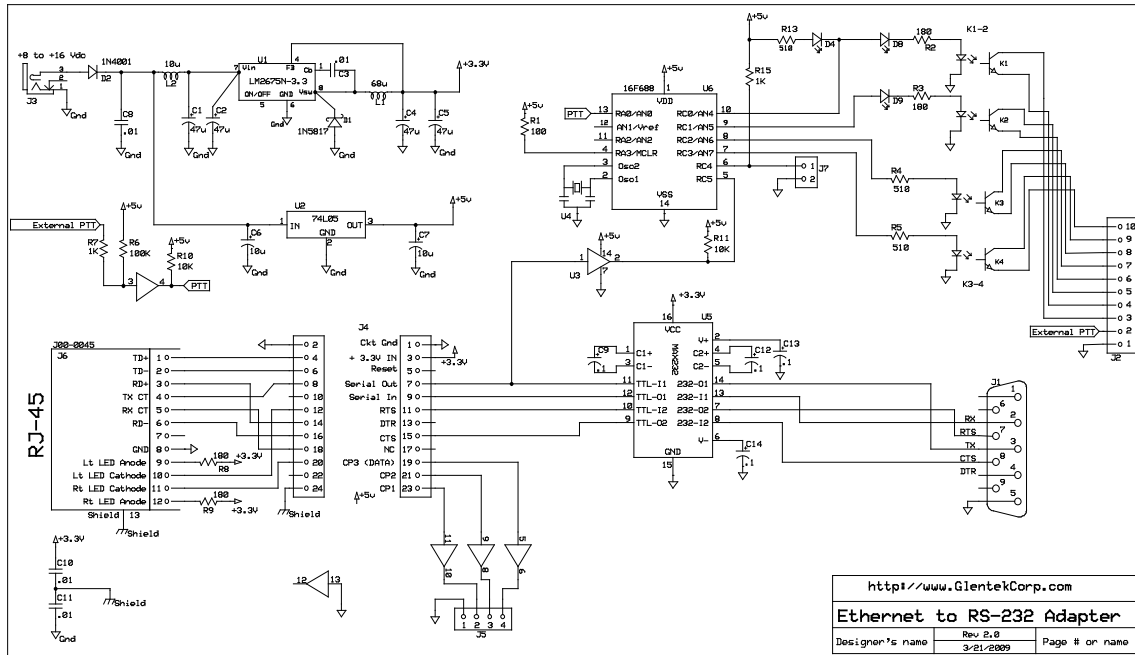

Additional Information

Outputs: Photo transistors. 80v, 40mA DC maximum

K1 activates upon detection of data on output connector. This can be used to turn on AC power to radio. Deactivates when activity is idle for >30 seconds for lock-up prevention.

K2 (PTT) is toggled upon receipt of code command 0xF1 on CI-V or RS-232 port. Many rig control software programs (e.g., HR Deluxe) allow for custom configurations of panel buttons. Configure one to send 0xF1 and the button will toggle K1. K1 is also activated by applying ground to the EXTERNAL PTT lead. K1 will deactivate if PTT is asserted for > 3 minutes via either the EXTERNAL PTT lead or the software command 0xF1. The time out will reset when PTT signal is released. If the PTT fault continues for another 4 minutes, K1 (radio power control) will cycle off for 10 seconds to attempt to clear a software reset fault.

K3 is toggled by a 0xF2 command on the CI-V or RS-232 line

K4 is toggled by a 0xF3 command on the CI-V or RS-232 line

DC power requirements: 8-18 Volts DC at 300mA. Center pin of the 3.5mm jack is positive.

The RJ45 jack includes isolation transformers that provide up to 1000 volts of isolation. This jack also provides shielding and RF filtering for the Ethernet connections.

The leads marked “+” on the K1-K4 outputs are connected to the collectors of the output transistors. The leads marked “-“ are connected to the emitters.

9600 baud operation : Install a strap in the 9600 baud location. No strap enables 19,200. The external pin decoder supports no other rates. The RTE will support other baud rates, but all parts of the system must be converted to the new rate. For example, if the rig control software is set to 9600 baud but the RTE is still set to 19,200 baud, the RTE output will still be 19,200. The RTE will accept any input data rate, but will only output at the rate set by its internal web server configuration.

The RTE will support hardware flow control as required by some Kenwood radios. This may be configured by settings in the internal configurations of the RTE.

The RTE-232 will also support most generic serial devices such as RS-232 enabled antenna rotators. The Internet introduces some latency (delay) but most devices are not sensitive to small (100-200mS) latency delays. However timing sensitive devices such as RS-232 or USB CW keyers may not function properly due to this latency issue.

CAUTION: External relays must have diode clamps installed across the relay coil to avoid damage to the optical couplers.

